

HC49/4H SMX CRYSTALS

ISSUE 9; 18 OCTOBER 1999

Delivery Options

- Common frequencies are available from stock. Please see p143 for details

Holder Style

- HC49/4H SMX crystals are resistance welded, hermetically sealed in an inert atmosphere with glass to metal seals securing the lead wires. The lead wires are formed into a gull wing and mounted on a plastic former
- Lower profiles available, please contact our sales office

General Specifications

- Load Capacitance (C_L): 10pF to 75pF or Series
- Drive Level: 0.5mW max
- Static Capacitance (C_0): 9pF max
- Ageing: ± 3 ppm typical per year

Standard Frequencies

- 3.579545MHz, 3.68640MHz, 4.0MHz, 4.91520MHz, 5.0MHz, 6.0MHz, 7.37280MHz, 8.0MHz, 8.1920MHz, 9.83040MHz, 10.0MHz, 11.05920MHz, 12.0MHz, 14.318180MHz, 14.74560MHz, 15.360MHz, 16.0MHz, 18.4320MHz, 19.66080MHz, 20.0MHz

Standard Frequency Tolerances and Stabilities

- ± 50 ppm, ± 100 ppm

Operating Temperature Ranges

- 0 to 50°C
- 10 to 60°C
- 20 to 70°C
- 30 to 80°C

Storage Temperature Range

- 40 to 85°C

Environmental Specification

- Shock: 981m/s² for 6ms, three shocks in each direction along three mutually perpendicular planes
- Vibration: 10 to 60Hz 0.75mm displacement, 60 to 500Hz 98.1m/s² acceleration, 30 minutes in each of three mutually perpendicular planes

Marking

- Frequency only

Minimum Order Information Required

- Frequency + Holder + Frequency Tolerance @ 25°C + Frequency Stability + Operating Temperature Range + Circuit Condition + Overtone Order

Outline in mm (inches)

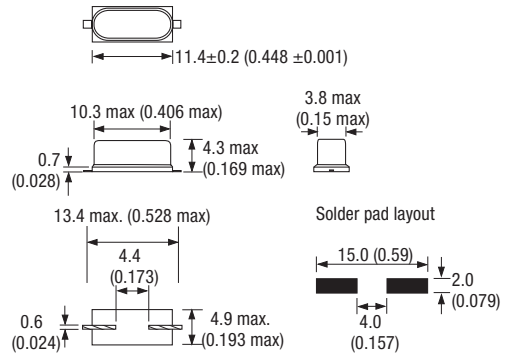

Typical Frequency vs Temperature Curves for various angles of AT-cut crystals

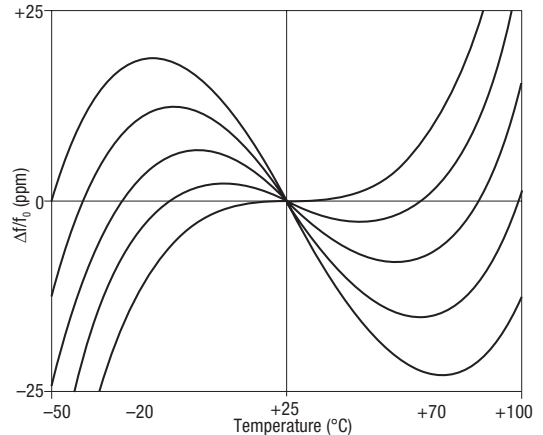

Typical Solder Condition - Infrared Reflow

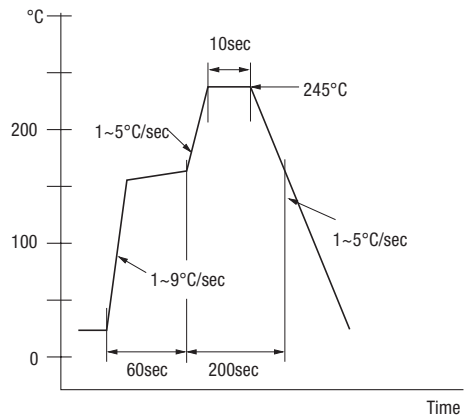

Electrical Specification - maximum limiting values

Frequency Range	Frequency Tolerance @ 25°C ±2°C	Operating Temperature Range	Frequency Stability Available Over Operating Temperature		ESR Max	Vibration Mode
			Minimum	Maximum		
3.50 to < 5.0MHz	±15ppm to ±100ppm	0 to 50°C	±15ppm	±100ppm	200Ω	Fundamental AT cut
		-10 to 60°C	±20ppm	±100ppm		
		-20 to 70°C	±20ppm	±100ppm		
		-30 to 80°C	±25ppm	±100ppm		
5.0 to < 8.0MHz	±15ppm to ±100ppm	0 to 50°C	±15ppm	±100ppm	120Ω	Fundamental AT cut
		-10 to 60°C	±20ppm	±100ppm		
		-20 to 70°C	±20ppm	±100ppm		
		-30 to 80°C	±25ppm	±100ppm		
8.0 to < 12.0MHz	±15ppm to ±100ppm	0 to 50°C	±10ppm	±100ppm	70Ω	Fundamental AT cut
		-10 to 60°C	±15ppm	±100ppm		
		-20 to 70°C	±15ppm	±100ppm		
		-30 to 80°C	±20ppm	±100ppm		
12.0 to < 25.0MHz	±15ppm to ±100ppm	0 to 50°C	±10ppm	±100ppm	50Ω	Fundamental AT cut
		-10 to 60°C	±15ppm	±100ppm		
		-20 to 70°C	±15ppm	±100ppm		
		-30 to 80°C	±20ppm	±100ppm		
25.0 to 32.0MHz	±15ppm to ±100ppm	0 to 50°C	±10ppm	±100ppm	30Ω	Fundamental AT cut
		-10 to 60°C	±15ppm	±100ppm		
		-20 to 70°C	±15ppm	±100ppm		
		-30 to 80°C	±20ppm	±100ppm		
25.0 to 40.0MHz	Inclusive with Frequency Stability	0 to 50°C	±50ppm	±100ppm	50Ω	Fundamental BT cut
		-10 to 60°C	±50ppm	±100ppm		
		-20 to 70°C	±100ppm	±100ppm		
		-30 to 80°C	±100ppm	±100ppm		
25.0 to 70.0MHz	±15ppm to ±100ppm	0 to 50°C	±15ppm	±100ppm	100Ω	3rd Overtone AT cut
		-10 to 60°C	±20ppm	±100ppm		
		-20 to 70°C	±20ppm	±100ppp		
		-30 to 80°C	±25ppm	±100ppm		

Outline in mm (inches) - Tape

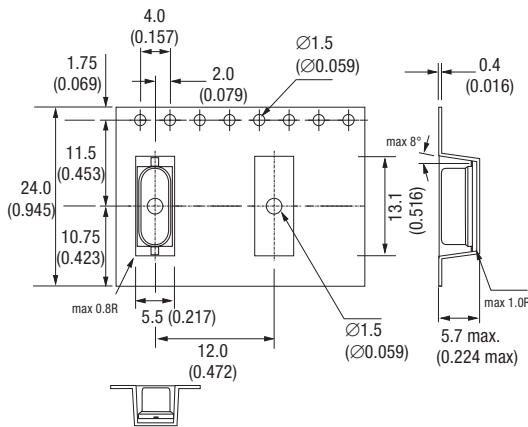

Outline in mm (inches) - Reel (scale 1:8)

